

















## ENGINE WIRES

C		RED	Alternator power	Route this wire (found in the 510476 kit) to the Megafuse and cut to length. Use ring terminals, shrink tubing and boot from 510476 kit and connect as shown on page 2.
D		RED	Alternator regulator	This is a small gauge wire that comes pre-installed in a white two way connector with a ring terminal on the other end. Feed the ring terminal through the boot with the above wire and attach to the output stud of you alternator.
E		BROWN	Battery warning light / alt regulator exciter	Plug this wire into the bulkhead in the location shown on page 2. Route to the alternator, cut to length and install terminal <b>E</b> . Insert brown wire into the open cavity next to the white connector on the red regulator wire listed above. Plug into regulator on alternator.
F				
G		PURPLE	Ignition switch	Route this wire to the S stud on your starter, cut to length, slide sleeve <b>K</b> over the wire and install ring terminal <b>C</b> . Slide sleeve <b>K</b> down over top of terminal and attach to the starter.
H		YELLOW (optional)	Resistor bypass	This wire is provided incase you are using an ignition system with a ballast resistor. Attach to the R stud on your starter, route to the coil side of your resistor and connect, as shown on page 2.
J		PINK	Coil power	Route this wire to the BAT (+) location on your coil. If using GM HEI distributor and coil, cut to length, install terminal <b>D</b> and insert into connector <b>J</b> . Plug into BAT (+) location on coil.
K		WHITE	Tach signal	Route this wire to the TACH or negative side (-) of your coil. If using GM HEI distributor and coil, cut to length, install terminal <b>E</b> and insert into connector <b>H</b> . Plug into tach location on coil.
M		TAN	Electric choke	If you are using a carburetor with an electric choke, plug this wire into the bulkhead in the location as shown on page 2. Route tan wire to the choke, cut to length, in many instances terminal <b>E</b> will work, but applications may vary. <b>NOTE:</b> You may need to make a ground wire for the choke assembly which has not been supplied.
N		DK BLUE	Oil pressure sender	Route this wire to your oil pressure sender (for gauge) or switch (for light). Cut to length and depending on the type of sender or switch we have provided terminal <b>E</b> and connector <b>F</b> for blade type connections or terminal <b>T</b> and sleeve <b>K</b> for ring type connections. Install the type that best suits your application.
O		DK GREEN	Temp sender	Route this wire to your water temperature sender (for gauge) or switch (for light). Cut to length, for most senders and switches install terminal <b>E</b> and insert into connector <b>F</b> but applications may vary.
P		RED	Main fuse panel feed	Route this wire to the Megafuse and cut to length. Use ring terminal, shrink tubing from 510476 kit. Connect as shown on page 1.
R				
S				
T				
U				



www.americanautowire.com 856-933-0801

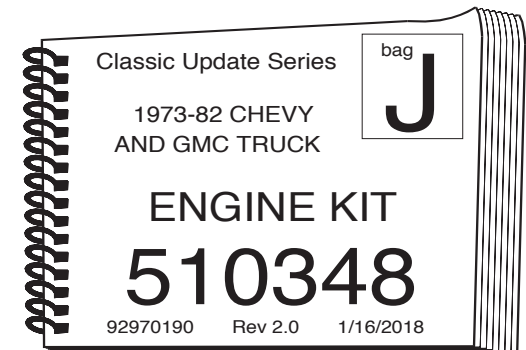

(MEGA FUSES, RING TERMINALS, SHRINK TUBING, AND BOOT FOUND IN 510476 KIT)

6 GA. RED (FROM 510476 KIT)

6 GA. RED

10 GA. RED (12 V BATTERY) (FROM 500668 KIT)

(BUSSBAR JUMPER FROM 510476 KIT)

(Battery cable to battery, not supplied)

optional connection for points cars

starter solenoid

oil sending unit

temp sender

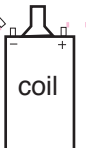

to coil + side



ballast resistor (resistor not included -only used on selected ignition systems)

distributor OR

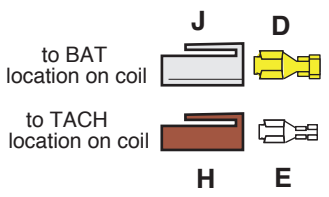
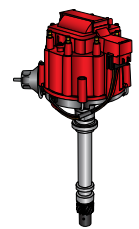

to BAT location on coil

to TACH location on coil

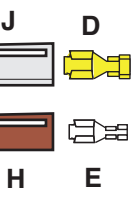

ALTERNATOR BOOT (FROM 510476 KIT)

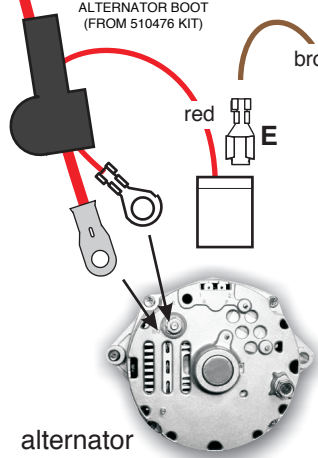

alternator

electric choke



tan

C K

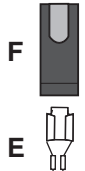
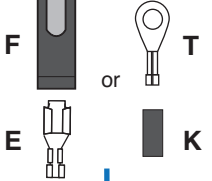

See page 3 for wiper connections

See page 4 for electric speedometer connections

bulkhead connector

wire entry view shown

apply silicone sealant after installing terminals

# WIPER MOTOR AND WASHER PUMP CONNECTIONS

## WIPER WIRES

1973 - 77

BLACK	Lo Speed ground	Route this wire to the wiper motor, cut to length, and install terminal <b>E</b> , insert into connector <b>P</b> in the slot shown below.
WHITE	Wiper feed (12V)	Route this wire to the wiper motor, cut to length, double with cut off portion into terminal <b>D</b> , and insert into connector <b>P</b> in the slot shown below. Route the other end of the cut off portion to the washer pump and cut to length, install terminal <b>E</b> and insert into connector <b>R</b> in the slot shown.
LT BLUE	Hi Speed ground	Route this wire to the wiper motor, cut to length, and install terminal <b>E</b> , insert into connector <b>P</b> in the slot shown below.
DK BLUE	Washer ground	Route this wire to the washer pump, cut to length, and install terminal <b>E</b> , insert into connector <b>R</b> in the slot shown below.

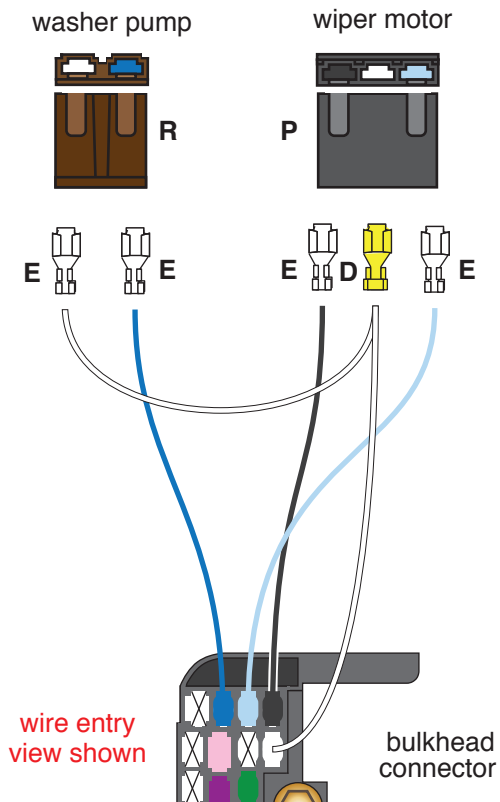

## WIPER WIRES

1978 - 82

BLACK	Lo Speed ground	Take the included wiper power pigtail <b>X</b> and insert the end terminals into connectors <b>M</b> and <b>N</b> as shown below. Route the black LO SPEED ground wire from the bulkhead to the pigtail <b>X</b> , cut to length, install terminal <b>E</b> and insert connector <b>G</b> . Connect to pigtail <b>X</b> .
WHITE	Wiper feed (12V)	Take the included wiper power pigtail <b>W</b> and insert the end terminals into connectors <b>M</b> and <b>O</b> as shown below. Route the white wiper power wire from the bulkhead to the pigtail <b>W</b> , cut to length, install terminal <b>E</b> and insert connector <b>G</b> . Connect to pigtail <b>W</b> .
LT BLUE	Hi Speed ground	Route this wire to the wiper motor, cut to length, and install terminal <b>U</b> , insert into connector <b>M</b> in the slot shown below.
DK BLUE	Washer ground	Route this wire to the washer pump, cut to length, and install terminal <b>S</b> , insert into connector <b>O</b> in the slot shown below.
BLACK/ LT BLUE	Wiper park	Plug this wire into the slot shown below in the main bulkhead. Route to the wiper motor park switch, cut to length, and install terminal <b>U</b> , insert into connector <b>N</b> in the slot shown below.

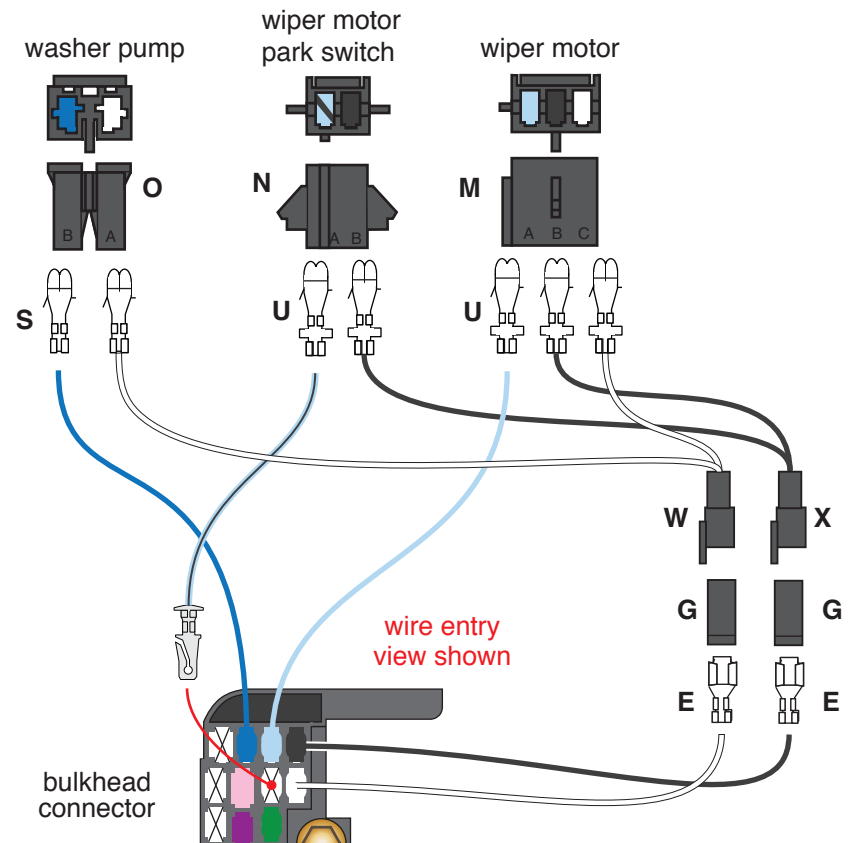

# TYPICAL VEHICLE SPEED SENSOR CONNECTIONS

Below are some general instructions for hooking up a Vehicle Speed Sensor for an electric speedometer. These instructions will ONLY be used in the event that you are utilizing an aftermarket electric speedometer. If your truck does NOT have an electric speedometer, this connection will NOT be used and you will not need to plug these wires into the bulkhead. It is best to consult the speedometer manufacturer's instructions if you have any questions.

- |                  |            |  |
|------------------|------------|--|
| Yellow           | VSS Ground | Plug into bulkhead in the location shown below, route to VSS, cut to length and connect to VSS neg. "--".    |
| Purple           | VSS Signal | Plug into bulkhead in the location shown below, route to VSS, cut to length and connect to VSS input.        |
| Purple/<br>White | VSS Power  | Plug into bulkhead in the location shown below, route to VSS, cut to length and connect to 12V power on VSS. |

